

# Pedestrian stacker truck 1.2 - 1.4 ton

## BT staxio

*W-series*

SWE120L

SWE140L



# Pedestrian stacker with elevating support arms

Specification for stacker trucks					SWE120L	SWE140L
Identification	1.1	Manufacturer			BT	BT
	1.2	Model			SWE120L	SWE140L
	1.3	Drive			Electric	Electric
	1.4	Operator type			Pedestrian	Pedestrian
	1.5	Load capacity/rated load	Q	kg	1200	1400
		Support arm capacity	Q	kg	1600	2000
	1.6	Load centre	c	mm	600	600
	1.8	Load distance, centre of support arm wheel to face of forks	x	mm	640	632
	1.9	Wheelbase	y	mm	1302	1302
Weight	2.1	Service weight including battery		kg	929	929
	2.2	Axle load, with load, drive/castor/support arm wheel		kg	450/340/1345	450/360/1525
	2.3	Axle load, without load, drive/castor/support arm wheel		kg	450/220/265	450/220/265
Wheels	3.1	Drive/castor/fork wheel			Friction/Vulkollan/Vulkollan *)	
	3.2	Wheel size, front		mm	Ø230x70	Ø230x70
	3.3	Wheel size, rear		mm	Ø85x74	Ø85x74
	3.4	Additional wheels (dimensions)		mm	Ø125x50	Ø125x50
	3.5	Wheels, number front/rear (x=driven wheels)			1x+2/4	1x+2/4
	3.6	Track width, front	b <sub>10</sub>	mm	550	550
	3.7	Track width, rear	b <sub>11</sub>	mm	390	390
Dimensions	4.2	Height, mast lowered	h <sub>1</sub>	mm	2135 *)	2160 *)
	4.3	Free lift	h <sub>2</sub>	mm	166 *)	166 *)
	4.4	Lift	h <sub>3</sub>	mm	3210 *)	3165 *)
		Lift height	h <sub>23</sub>	mm	3300 *)	3255 *)
	4.5	Height, mast extended	h <sub>4</sub>	mm	3720 *)	3725 *)
	4.6	Initial lift	h <sub>5</sub>	mm	120	120
	4.8	Stand height (optional platform)	h <sub>7</sub>	mm	150	150
	4.9	Height of tiller in drive position, min./max.	h <sub>14</sub>	mm	865/1235	865/1235
	4.15	Height, fork lowered	h <sub>13</sub>	mm	90	90
	4.19	Overall length	l <sub>1</sub>	mm	1910	1910
	4.20	Length to face of forks	l <sub>2</sub>	mm	753	761
	4.21	Overall width	b <sub>1</sub>	mm	770	770 *)
	4.22	Fork dimensions	s/e/l	mm	60/180/1150 *)	70/180/1150 *)
	4.24	Fork-carriage width	b <sub>3</sub>	mm	674	674
	4.25	Width over forks	b <sub>5</sub>	mm	570 *)	570 *)
	4.31	Ground clearance, with load, below mast	m <sub>1</sub>	mm	22	22
	4.32	Ground clearance, centre of wheelbase	m <sub>2</sub>	mm	22	22
4.33	Aisle width for pallets 1000x1200 crossways	A <sub>st</sub>	mm	2293	2297	
4.34	Aisle width for pallets 800x1200 lengthways	A <sub>st</sub>	mm	2281	2288	
4.35	Turning radius	W <sub>a</sub>	mm	1393	1393	
Performance data	5.1	Travel speed, with/without load		km/h	6/6	6/6
	5.2	Lift speed, with/without load		m/s	0.12/0.27	0.11/0.27
	5.3	Lowering speed, with/without load		m/s	0.38/0.32	0.37/0.32
	5.8	Max. gradeability, with/without load		%	9/12 <sup>1)</sup>	8/12 <sup>1)</sup>
	5.10	Service brake			Electromagnetic	Electromagnetic
Electric motor	6.1	Drive motor rating S2 60 min		kW	1.5	1.5
	6.2	Lift motor rating at S3 15%		kW	2.2 <sup>2)</sup>	2.2 <sup>2)</sup>
	6.4	Battery voltage/nominal capacity K <sub>s</sub>		V/Ah	24/225 *)	24/225 *)
	6.5	Battery weight		kg	219 *)	219 *)
Others	8.1	Type of drive control			BT Powerdrive	BT Powerdrive

<sup>1)</sup> Measured according to company standard.

<sup>2)</sup> S3 6%.

\*) Further alternatives are available and will produce other values.

Data is based on standard configurations: Medium battery compartment,  
h<sub>23</sub> = 3300 mm (SWE120L) and 3255 mm (SWE140L) Duplex Tele Panoramic View mast.

Truck performance and dimensions are nominal and subject to tolerances.

BT Products AB products and specifications are subject to change without notice.

# Battery dependent dimensions

Dimensions		Battery change		SWE120L				SWE140L			
				Lift out		Sideways		Lift out			Sideways
		Compartment	Medium	Large	DIN	Large	Medium	Large	DIN	Large	
1.9	Wheelbase	y	mm	1302	1352	1592	1352	1302	1352	1592	1352
4.19	Overall length	$l_1$	mm	1910	1960	1960	1960	1910	1960	1960	1960
	without platform		mm	1995/2385	2045/2435	—	2045/2435	1995/2385	2045/2435	—	2045/2435
4.20	Length to face of forks	$l_2$	mm	753	803	810	803	761	811	810	811
	without platform		mm	838/1228	888/1278	—	888/1278	846/1236	896/1286	—	896/1286
4.33	Aisle width for pallets 1000x1200 crossways	$A_{st}$	mm	2293	2343	2573	2449	2297	2347	2573	2347
	without platform		mm	2378/2778	2428/2828	—	2428/2828	2382/2782	2432/2832	—	2432/2832
4.34	Aisle width for pallets 800x1200 lengthways	$A_{st}$	mm	2281	2331	2552	2331	2288	2338	2552	2338
	without platform		mm	2366/2766	2416/2816	—	2416/2816	2373/2773	2423/2823	—	2423/2823
4.35	Turning radius	$W_a$	mm	1293	1443	1698	1443	1393	1443	1698	1443
	without platform		mm	1478/1878	1528/1928	—	1528/1928	1478/1878	1528/1928	—	1528/1928
6.4	Battery voltage, nominal capacity $K_5$		V/Ah	24/225	24/300	24/375	24/260	24/225	24/300	24/375	24/260
6.5	Battery weight, min.—max.		kg	189—250	230—280	230—305	209—250	189—250	230—280	230—305	209—250

# Mast dimensions

SWE120L		Simplex	Duplex Tele				Dupl. Tele Panoram. View				Duplex HiLo				Triplex HiLo					
$h_{23}$	Lift height (h13+h3)	mm	1400	1700	2700	2900	3300	3700	4150	2700	2900	3300	3700	4150	2700	2900	3300	3700	4150	4500
$h_3$	Lift	mm	1310	1610	2610	2810	3210	3610	4060	2610	2810	3210	3610	4060	2610	2810	3210	3610	4060	4410
$h_1$	Height, mast lowered	mm	1825	2125	1840	1940	2140	2340	2565	1835	1935	2135	2335	2560	1835	1935	2135	2335	2560	1695
$h_2$	Free lift, ground to top of forks	mm	1400	1700	166	166	166	166	166	166	166	166	166	166	1420	1520	1720	1920	2144	1270
$h_4$	Height, mast extended	mm	1825	2125	3125	3325	3725	4125	4575	3120	3320	3720	4120	4570	3341	3341	3741	4141	4591	3747

SWE140L		Duplex Tele Panoramic View				Duplex HiLo				Triplex HiLo							
$h_{23}$	Lift height (h13+h3)	mm	2655	2855	3255	3655	4105	2655	2855	3255	3655	4105	3255	3655	4105	4455	4755
$h_3$	Lift	mm	2565	2765	3165	3565	4015	2565	2765	3165	3565	4015	3165	3565	4015	4365	4665
$h_1$	Height, mast lowered	mm	1860	1960	2160	2360	2585	1835	1935	2135	2335	2560	1695	1829	1979	2095	2195
$h_2$	Free lift, ground to top of forks	mm	166	166	166	166	166	1374	1474	1674	1874	2099	1224	1358	1508	1624	1724
$h_4$	Height, mast extended	mm	3125	3325	3725	4125	4575	3141	3341	3741	4141	4591	3747	4149	4599	4947	5247

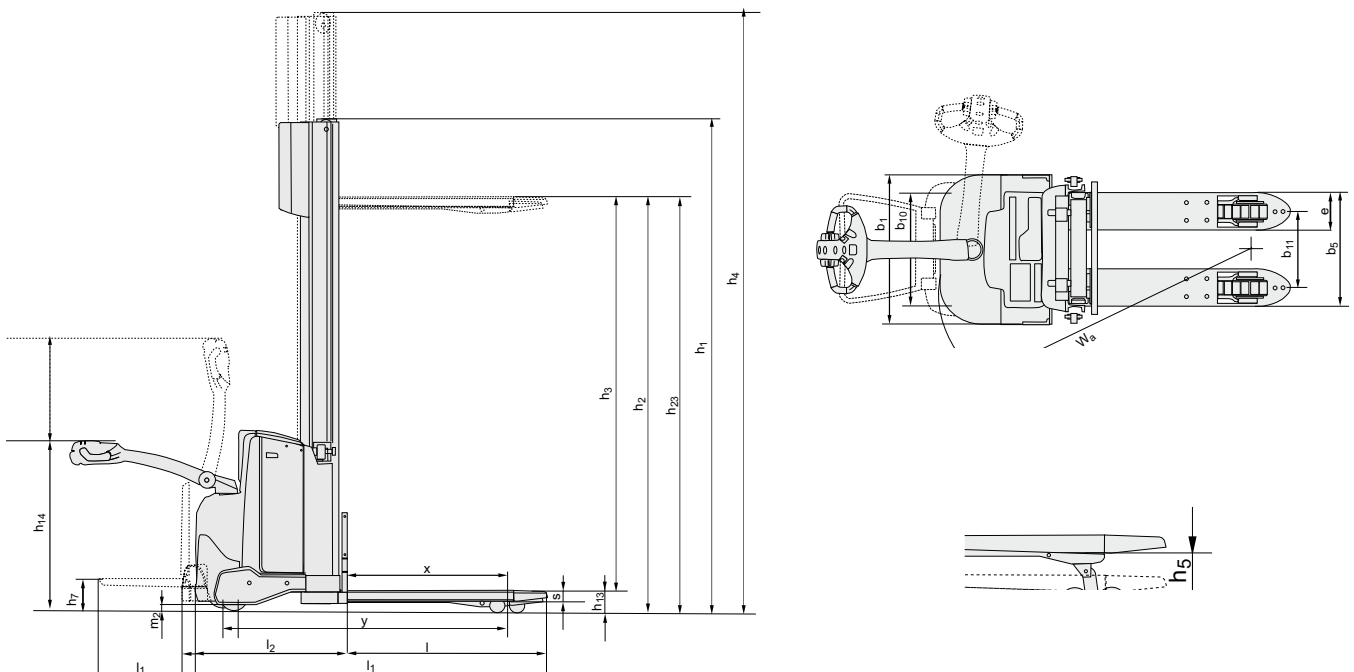

---

## Truck features:

- BT Powerdrive System
- Fingertip controls
- Electronic braking system
- Electronic speed control
- Operator safety
- Storage compartments
- Automatic switch-off
- Click-2-creep
- Programmable performance
- Easy access for maintenance
- Built in charger (option)
- Sensilift (option)
- Flip-up operator platform (option)
- Toyota I\_site: truck fleet management system (option)
- Hydraulic oil for low temperatures (option)

